

**ProThermetic Sprint**  
**Electric Tilting Pressure Braising Pan,**  
**90lt Hygienic Profile, Freestanding with**  
**CTS**

ITEM # \_\_\_\_\_

MODEL # \_\_\_\_\_

NAME # \_\_\_\_\_

SIS # \_\_\_\_\_

AIA # \_\_\_\_\_

**586910 (PUET09KCES)**

Electric tilting Pressure Braising Pan 90lt (h), steam condensation function, core temperature sensor, auto. H/ C water filling with swivelling arm, spray gun, rear closing kit, GuideYou Panel, freestanding

**586911 (PUET09KLES)**

Electric tilting Pressure Braising Pan 90lt (h), splashback, steam condensation function, core temperature sensor, auto. H/ C water filling with swivelling arm, spray gun, rear closing kit, GuideYou Panel, freestanding

### Short Form Specification

**Item No.** \_\_\_\_\_

AISI 304 stainless steel construction. GN compliant pan size; 18mm thick pan bottom (15mm mild steel and 3 mm AISI 316 stainless steel). Insulated and counterbalanced lid. Motorized tilting with variable speed control. Pan can be tilted beyond 90° to completely empty the food. The electric heating elements are mounted under the well. Safety thermostat protects the pan from overheating. A precise, electronic control of pan bottom temperature ensures fast reaction and exact adherence to preselected cooking temperatures between 50° and 250°C. It can be used for poaching or steaming (with the lid open); simmering and boiling (with open or closed lid); PRESSURE cooking of multiple produces, thanks to the use of suspended GN 1/1 containers. Automatic steam elimination at the end of the cooking cycle. TOUCH control panel. GuideYou Panel easily guides the user during multiphase recipes. Built in temperature sensors for precise control of cooking process. Core Temperature Sensor (CTS): multi-sensor food probe ensures exact core temperature measurement with optimum cooking results and reduced weight loss. Machine configuration including swivel arm with automatic water filling, spray gun and rear closing panel. IPX6 water resistant. Installation: Free-standing or Standing against a wall. Installation options (not included): floor mounted on 200mm high feet or a plinth which can be either steel or masonry construction. Dedicated model equipped with splashback as standard. Connectivity available.

### Main Features

- Multifunctional cooking appliance used for roasting, pot-roasting, braising, simmering, boiling and steaming.
- Delivered with:
  - swivel arm with automatic hot/cold water filling
  - spray gun
  - rear closing panel
  - C-board (backsplash for the relevant model)
- Pan size is GN compliant.
- "Pressure function": once the pressure lid is locked, the system automatically regulates itself.
- Cooking with a working pressure of 0.45 bar reduces cooking times.
- Safety valve on the lid avoids overpressure in the food compartment.
- Core Temperature Sensor (CTS): multi-sensor food probe, 6 sensors, 0,5 °C accuracy, provides efficient temperature control. The power is supplied as and when required to keep the set temperature value without exceeding it and once reached, the food is ready to be served.
- Motorized, variable pan tilting with "SOFT STOP". Tilting and pouring speeds can be precisely adjusted. Pan can be tilted over 90° to facilitate pouring and cleaning operations.
- Easy to clean cooking surface due to large-radius edges and corners.
- Thermoblock heating system for even temperature distribution and high temperature stability.
- Optimum heat distribution in the food provides best cooking results in terms of taste, colour and consistency and in terms of vitamin preserving.
- Pan bottom with two individually adjustable heating zones, each with a temperature sensor.
- Built-in temperature sensor provides efficient temperature control: the power is supplied as and when required to keep the set temperature value without exceeding it.
- No overshooting of cooking temperatures, fast reaction.
- USB connection to easily update the software, upload/download recipes and download HACCP data.
- IPX6 water resistant.

### Construction

- Multipurpose non-stick cooking surface in 18 mm thick compound: 3 mm shot-blasted 1.4404 (AISI 316L) stainless steel surface, seamlessly welded to 15 mm mild steel bottom.
- 15 mm thick heating layer concealed below the entire pan bottom, to provide high thermal diffusion and heat storage properties.
- External panelling and internal frame made of 1.4301 (AISI 304) stainless steel.
- Minimised presence of narrow gaps for easier cleaning of the sides to meet the highest hygiene standards.
- Heatproof handle with non-slip surface.
- Double-lined insulated lid in 1.4301 (AISI 304)

**APPROVAL:** \_\_\_\_\_

stainless steel mounted on the cross beam of the unit, counterbalanced by a hinge that remains open in all positions.

- Pressure lid fitted with a proven fast-acting lock which is simple and safe in operation. Safety mechanism prevents lid from opening, even in case of voluntary attempt, when cooking under pressure.
- Highly-visible and bright led TOUCH control panel features user-friendly icons and intuitive self-explanatory command options. Display visualizes:
  - Actual and set temperature
  - Set and remaining cooking time
  - Pre-heating phase (if activated)
  - GuideYou Panel (if activated)
  - Deferred start
  - Soft Function to reach the target temperature smoothly
  - 9 Power Control levels from simmering to fierce boiling
  - Pressure mode (in pressure models)
  - Stirrer ON/OFF settings (in round boiling models)
  - Error codes for quick trouble-shooting
  - Maintenance reminders
- Possibility to store recipes in single or multiphase cooking process, with different temperature settings.
- GuideYou Panel - activated by the user via settings - to easily follow the multiphase recipes, granting a proper and controlled cooking and a better appliance optimization.  
The system will provide maintenance reminders, in line with ESSENTIA program, helping the user to properly take care of the product, avoiding downtimes.
- Both "Boiling" or "Braising" mode functions available.
- Can be prearranged for energy optimisation or external surveillance systems (optional).
- 98% recyclable by weight; packaging material free of toxic substances.
- Lateral surface of the vessel in DIN 1.4301/AISI 304.

### User Interface & Data Management

- Connectivity ready, to connected appliances from remote via cable and data monitoring, including HACCP (requires optional accessory).

### Sustainability



- Overnight cooking: saving energy and time.
- High-quality thermal insulation of the pan saves energy and keeps operating ambient temperature low.

### Included Accessories

- 1 of C-board (length 1200mm) for tilting units - factory fitted (only for 586911) PNC 912184
- 1 of Rear closing kit for tilting units - against wall - factory fitted PNC 912704
- 1 of Automatic water filling (hot and cold) for tilting units - to be ordered with water mixer - factory fitted PNC 912735
- 1 of Spray gun for tilting units - freestanding (height 700mm) - factory fitted PNC 912776

### Optional Accessories

- Strainer for dumplings for all tilting & stationary braising and pressure braising pans (except 80lt) and for all stationary rectangular and 100lt round boiling pans PNC 910053

- Scraper for dumpling strainer for boiling and braising pans PNC 910058
- Suspension frame GN1/1 for rectangular boiling and braising pans PNC 910191
- Base plate 1/1 GN for braising pans PNC 910201
- Perforated container with handles 1/1GN (height=100mm) for boiling and braising pans PNC 910211
- Perforated container with handles 1/1GN (height 150mm) for boiling and braising pans PNC 910212
- Stainless steel plinth for tilting units - against wall - factory fitted PNC 911425
- Small perforated shovel for braising pans (PFEN/PUEN) PNC 911577
- Small shovel for braising pans (PFEN/PUEN) PNC 911578
- Bottom plate with 2 feet, 200mm for tilting units (height 700mm) - factory fitted PNC 911930
- MOBILE KIT TxxT/PxxT (VAR.width=S-Code) PNC 912460
- Power Socket, CEE16, built-in, 16A/400V, IP67, red-white - factory fitted PNC 912468
- Power Socket, CEE32, built-in, 32A/400V, IP67, red-white - factory fitted PNC 912469
- Power Socket, SCHUKO, built-in, 16A/230V, IP68, blue-white - factory fitted PNC 912470
- Power Socket, TYP23, built-in, 16A/230V, IP55, black - factory fitted PNC 912471
- Power Socket, TYP25, built-in, 16A/400V, IP55, black - factory fitted PNC 912472
- Kit energy optimization and potential free contact - factory fitted PNC 912737
- Mainswitch 25A, 4mm<sup>2</sup> - factory fitted PNC 912773
- Food tap 2" for tilting braising pans (PUET-PFET) - factory fitted PNC 912780
- Emergency stop button - factory fitted PNC 912784
- Scraper without handle for braising pans (PFEX/PUEX) PNC 913431
- Scraper with vertical handle for braising pans (PFEX/PUEX) PNC 913432
- Strainer for tilting pressure braising pan, 3 GN (10/170l) (only for 586910) PNC 913574
- Connectivity kit for ProThermetic Boiling and Braising Pans ECAP - factory fitted PNC 913577
- Stainless steel dividing panel, 900x800mm, (it should only be used between Electrolux Professional thermaline Modular 90 and thermaline C90) (only for 586910) PNC 913673

Front

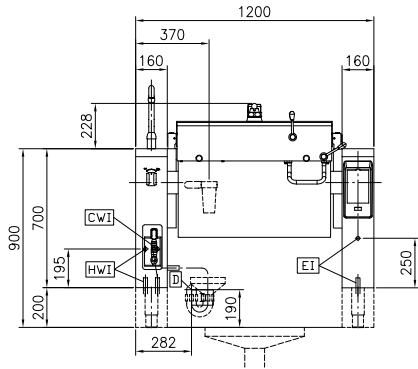

Side

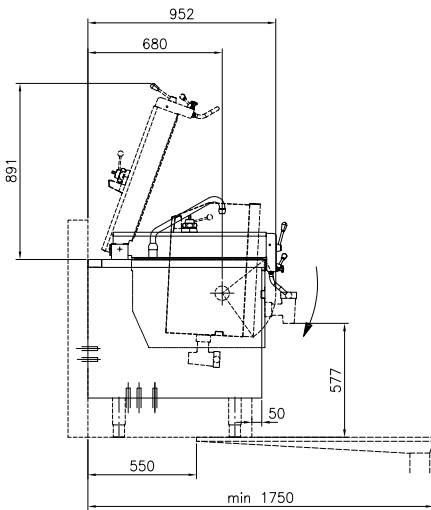

CWI1 = Cold Water inlet 1 (cleaning)      HWI = Hot water inlet  
 D = Drain  
 EI = Electrical inlet (power)

Top

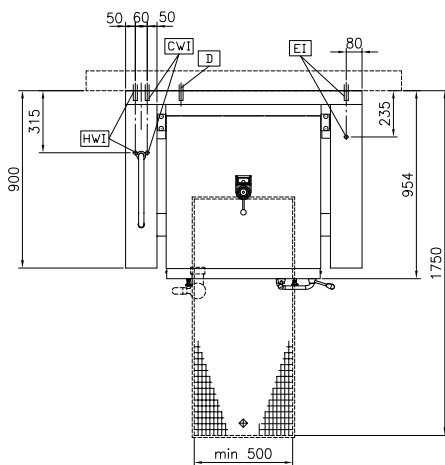

Front

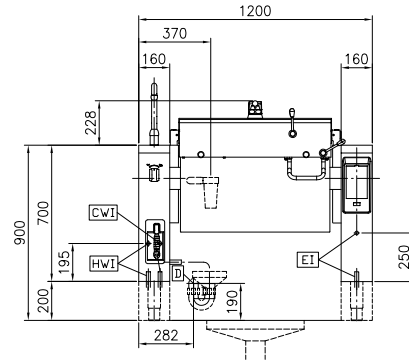

Side

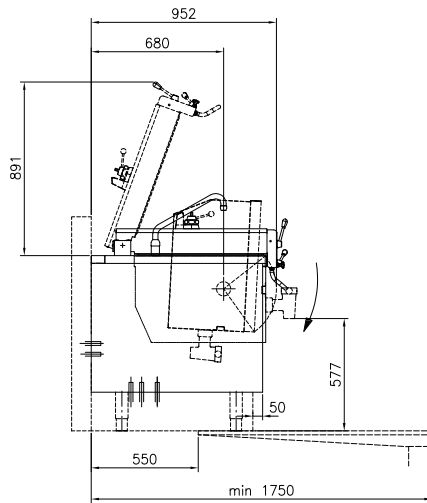

CWI1 = Cold Water inlet 1 (cleaning)      HWI = Hot water inlet  
 D = Drain  
 EI = Electrical inlet (power)

Top

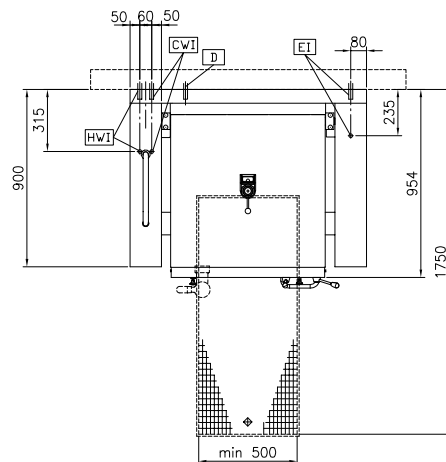

**Electric**

Supply voltage: 400 V/3N ph/50/60 Hz  
Total Watts: 15.5 kW

**Installation:**

Type of installation: FS on concrete base;FS on feet;On base;Standing against wall

**Key Information:**

Working Temperature MIN: 50 °C  
Working Temperature MAX: 250 °C  
Vessel (rectangle) width: 680 mm  
Vessel (rectangle) height: 274 mm  
Vessel (rectangle) depth: 558 mm  
External dimensions, Width: 1200 mm  
External dimensions, Depth: 900 mm  
External dimensions, Height: 700 mm  
Net weight: 240 kg  
Configuration:  
586910 (PUET09KCES) Rectangular;Tilting  
586911 (PUET09KLES) Rectangular;Tilting;With splashback  
Net vessel useful capacity: 90 lt  
Tilting mechanism: Automatic  
Double jacketed lid: ✓  
Heating type: Direct